

DC Motors

D4566-4535

Issue 09:CN3815

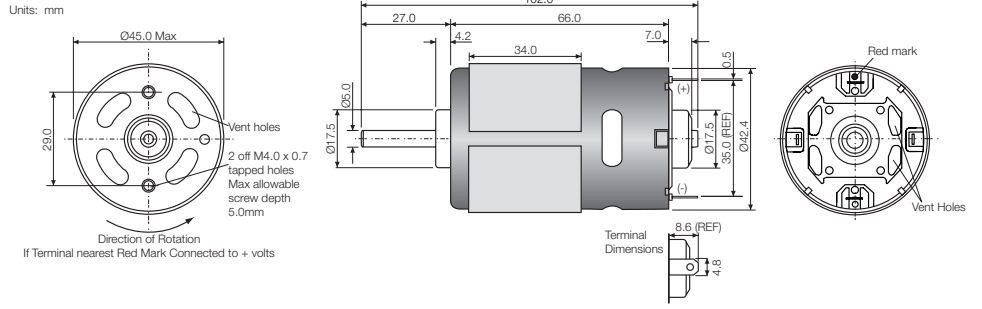

Model Number	Performance									
	Volts V	No Load		Maximum Efficiency				Stall		Max Power W
		Speed rpm	Current A	Speed rpm	Current A	Torque mNm	Output W	Torque mNm	Current A	
D4566-4535	24	12000	1.10	9300	4.46	75.9	73.9	447.4	22.0	140.6

Performance characteristics and general specification are from calculated data.

Characteristics

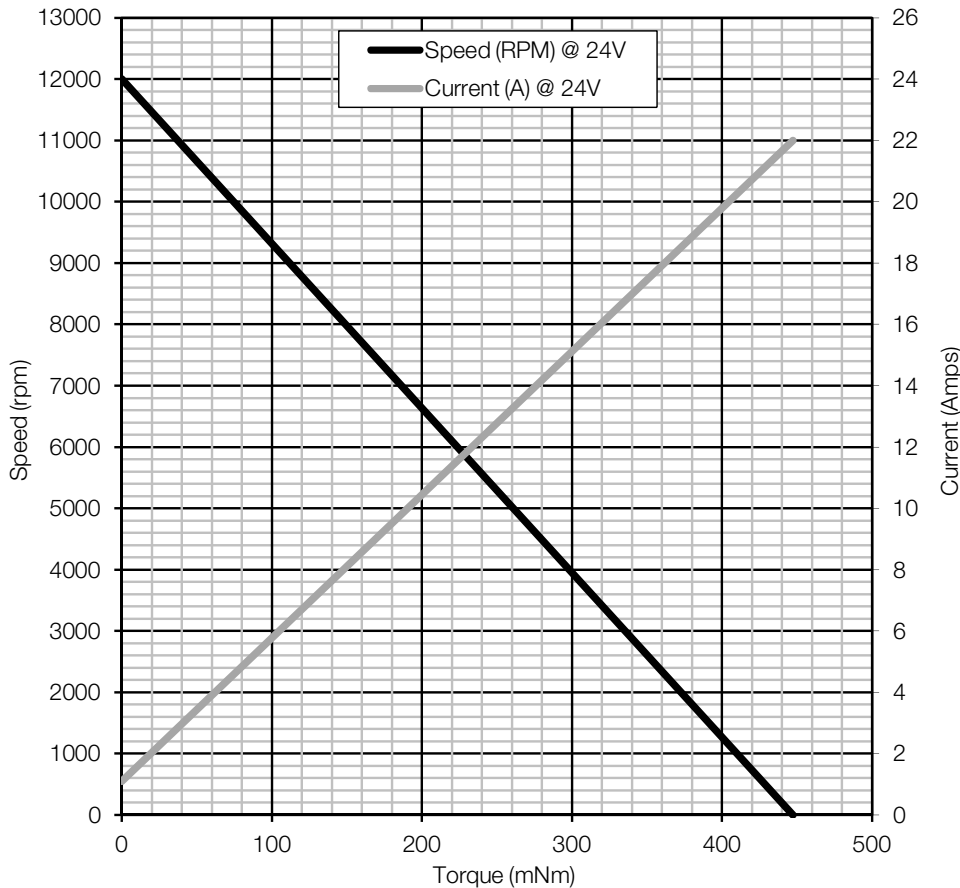

General Specification

Bearings	Local Ball race front Sintered rear
Brushes	Carbon
Rotation	Bi-directional
Number of poles	5
Operating voltage	12 V to 24 V
Nominal resistance	3.6 Ω
Typical detent torque	16 mNm
Suppression	Internal ring varistor
Weight	360 g

Contact:

www.rotalink.com
info@rotalink.com
 T: +44 (0)1460 72000

Rotalink Limited
 Cropmead, Crewkerne
 Somerset TA18 7HQ, UK

www.rotalink.com