

# Hybrid Stepping Motors

M174518K415

Issue 02

# Rotalink

Miniature Motors, Transmission and Control

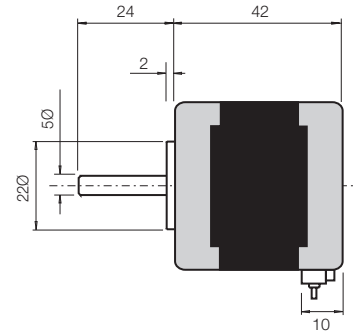
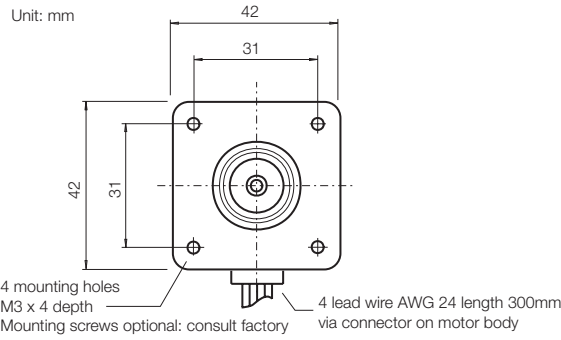

Model Number	Phase voltage (V)	Phase current (A)	Phase resistance ( $\Omega$ )	Phase inductance (mH)	Detent torque (mNm)	Winding
M174518K415	8.6	0.57	15.0	28.0	19.6	Bi-polar

## General Specification

Holding Torque	320.0mNm
Step angle	1.8°
Step accuracy	± 5%
Rotor Inertia	7.5 kgm <sup>2</sup> x10 <sup>-6</sup>
Temperature rise	80°C (max.)
Ambient temp. range	-20°C to +50°C
Insulation resistance	100M $\Omega$ (min) at 500V DC
Dielectric strength	500V AC 1min
Radial play	0.02mm (max.) with 450g load
Weight	320g

## Characteristics

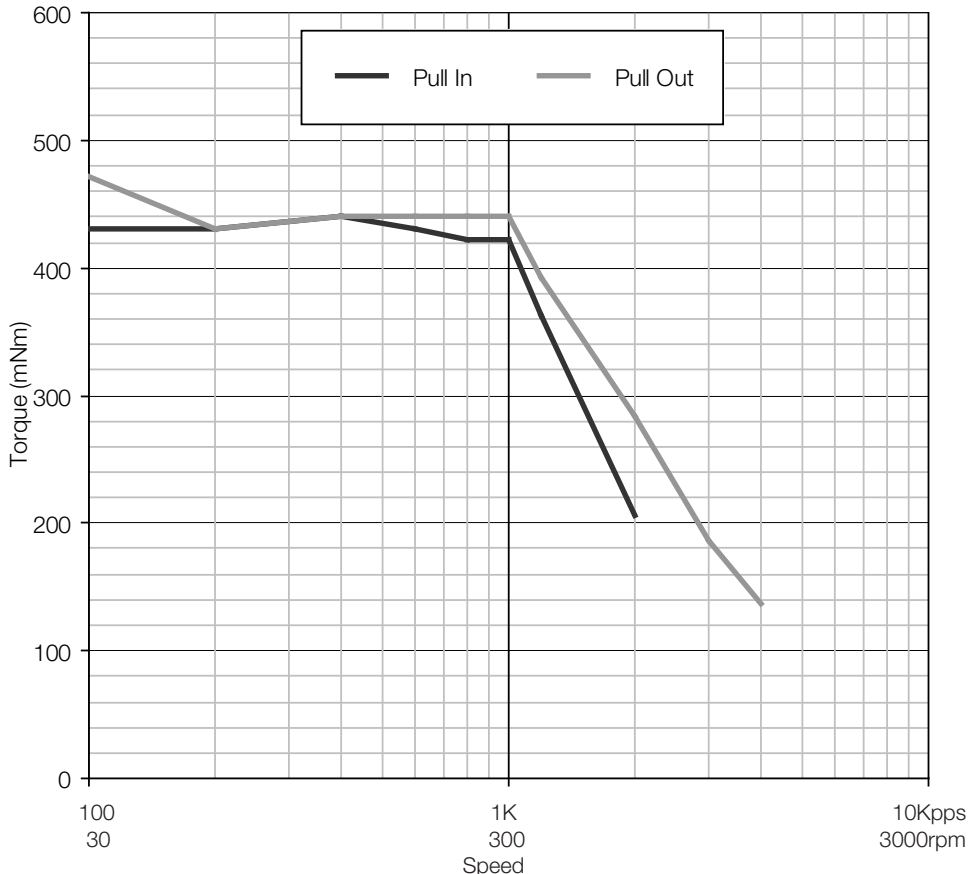

## Full step bi-polar sequence

CW dir.	Step 1	Step 2	Step 3	Step 4
Blue	-	+	+	-
Orange	+	-	-	+
Red	+	+	-	-
Yellow	-	-	+	+

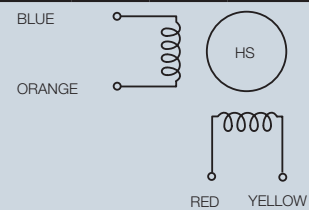

## Contact:

www.rotalink.com  
info@rotalink.com  
T: +44 (0)1460 72000  
F: +44 (0)1460 74278

Rotalink Limited  
Cropmead, Crewkerne  
Somerset TA18 7HQ, UK

www.rotalink.com